

Interface Control Document – Mechanical  
30 mNm-sec Reaction Wheel  
Sinclair Interplanetary  
February 11, 2017, Rev 1.1

## 1. Scope

This document describes the mechanical interface for the 30 mNm-sec reaction wheels built by Sinclair Interplanetary and SFL. For it to be relevant to your wheel, your part number must be of the form:

RW-0.03-xx-xxxxx-x-x-x

For additional interface definitions see:

- The electrical ICD for your particular electronics unit
- The software ICD for your particular software load

## 2. Mechanical Drawings

### 2.1. Top View

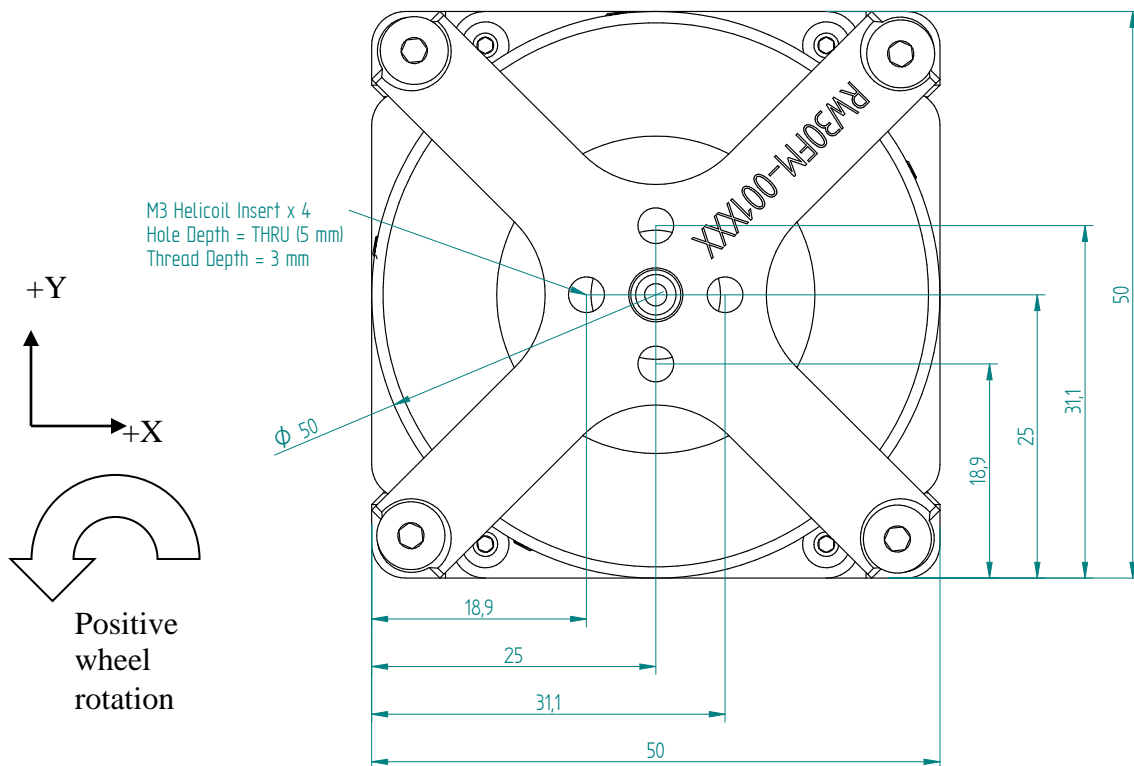

The X and Y axes are defined as shown in the figure. The Z-axis (illustrated in the following figures) completes the right-handed set. The rotation arrow shows the

direction of wheel rotation that is considered positive speed. Rotation in the opposite direction is considered negative wheel speed.

### 2.2. Side View

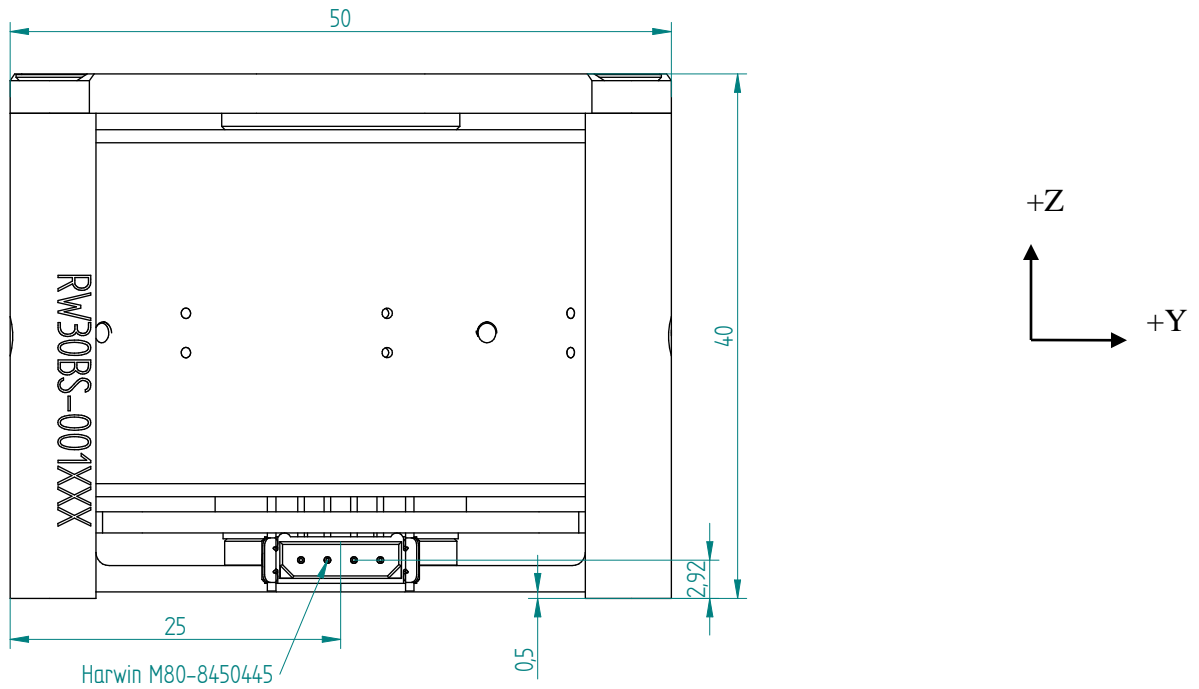

### 2.3. Front View

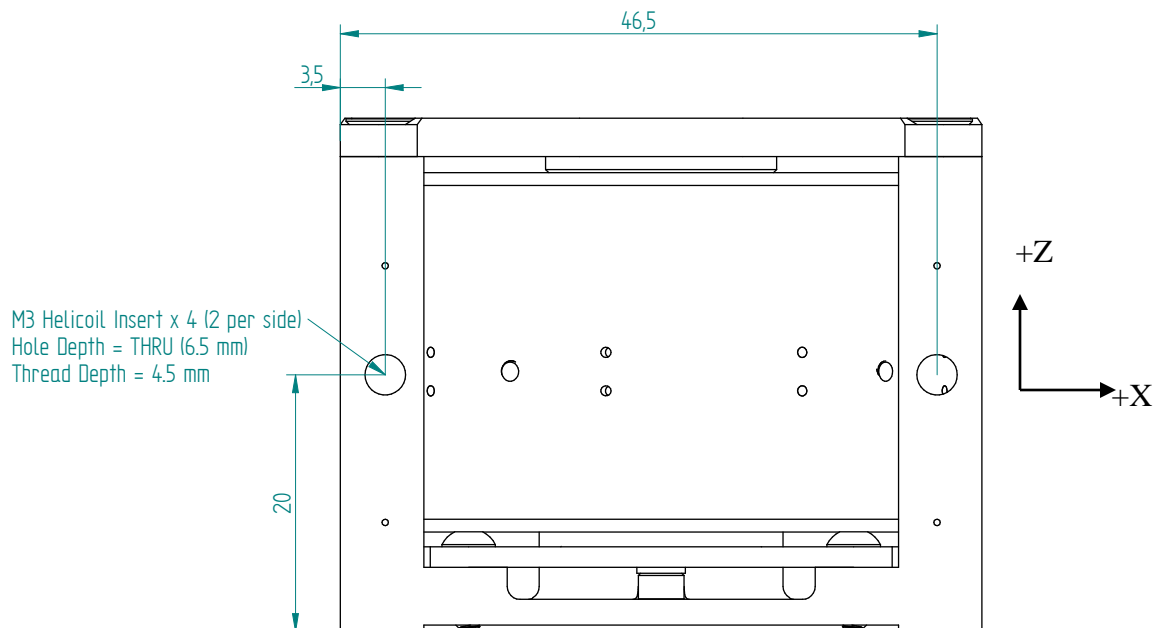

## 2.4. Bottom View

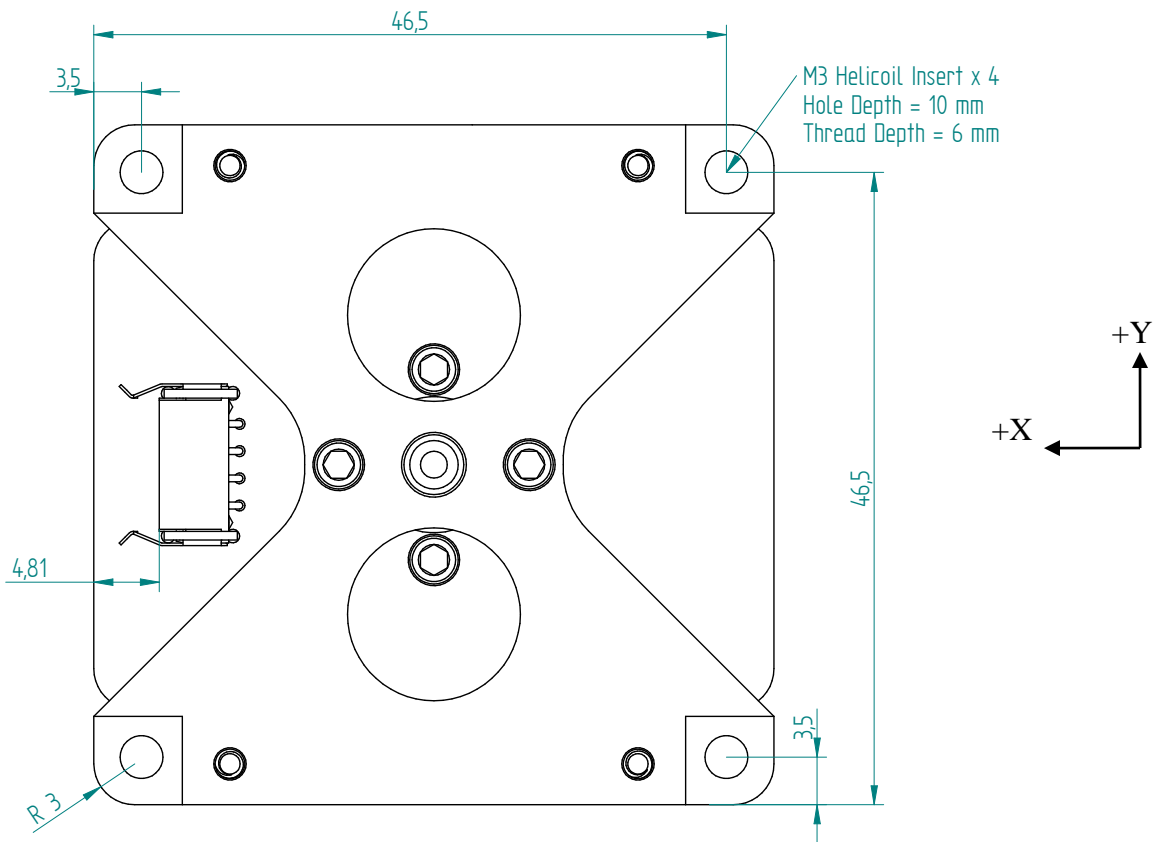

## 3. Materials

The following materials are used as structural elements in the reaction wheel.

- Aluminum 6061-T6, with yellow chemical film coating, for primary structural elements
- Nitronic 60™ (UNS S21800) stainless steel helical inserts for all internal threads
- Windform LX 2.0 composite polymer as an insulator in the motor
- Windform XT 2.0 composite polymer as a magnet positioner in the rotor
- Samarium Cobalt, with nickel overplate, in the rotor magnets
- Stainless Steel 416, for the bulk of the rotor

All of the materials and processes for the wheel have been selected for compatibility with high vacuum and low outgassing requirements.

## 4. Mounting

The wheel has mounting points on the bottom, front, back, and top surfaces. This flexibility allows the customer to mount a number of orthogonal wheels to a plate while reducing the need for additional brackets. All mounting holes are threaded for M3x0.5. The wheel mounting points provide mechanical, thermal and electrical bonding paths.

The bottom mounting points may be used alone, as the four widely-spaced holes provide a solid anchor for the wheel. Alternatively, a combination of the top and front or back holes can be used to securely mount the wheel.

Be careful when using the front or back mounting points that the spacecraft structure does not interfere with the rotor. The rotor diameter reaches all the way to the edge of the wheel footprint, so it cannot be simply mounted to a flat plate. Some form of standoff is required.

## 5. Electrical Connector

The electrical connector is mounted to the underside of the circuit board. Specific details on the connector may be found in the electrical ICD. The type and polarity of connector shown in this document is for illustration only.

## 6. Mass Properties

The mass of the complete wheel assembly is 185 grams. The mass center is close to the geometric center.

## 7. Magnetic Properties

The rotor contains a 10-pole magnet array on its inner surface. The stainless steel of the rotor prevents the vast majority of the field lines from leaving the wheel. The large number of poles means that the field decays very quickly with increasing distance. There is no dipole moment, and so no unwanted attitude torques upon the spacecraft.

## 8. Pressure Environment

The reaction wheel is designed to operate in the vacuum of space, and in the atmosphere of a terrestrial laboratory environment. The bearings are lubricated with space-grade grease and will give many years of service on-orbit. This lubricant is not moisture sensitive, and is not degraded by atmospheric operation.

The wheel has not been designed to operate through critical pressure, and has not been tested for coronal discharge. For safety it should be unpowered while the host spacecraft is attached to the launch vehicle.

## 9. Thermal Environment

|                       |                  |
|-----------------------|------------------|
| Operating Temperature | -40 °C to +75 °C |
| Survival Temperature  | -40 °C to +85 °C |

The temperature is defined as the temperature of the base plate in the nominal mounting configuration.

Note that the motor magnets are high-temperature samarium-cobalt and are at no risk of demagnetization from reasonable spacecraft temperatures.

## **10. Vibration and Shock Environment**

The reaction wheel has been designed to be compatible with the vibration and shock environment of most launch vehicles. Please contact the factory for further details.

The total vibration lifetime of the wheel bearings is limited. The user must be careful not to over-test flight wheels during unit-level or spacecraft-level acceptance testing. Test plans should be designed so that the sum of the acceptance testing plus the actual launch vibration does not exceed the duration of the qualification tests.

## **11. Contamination Environment**

This wheel is not hermetically sealed, and so great care must be taken to avoid contamination of the electronics and the bearings by dust and debris. It should be bagged when not used, and handled only in a clean-room environment.